

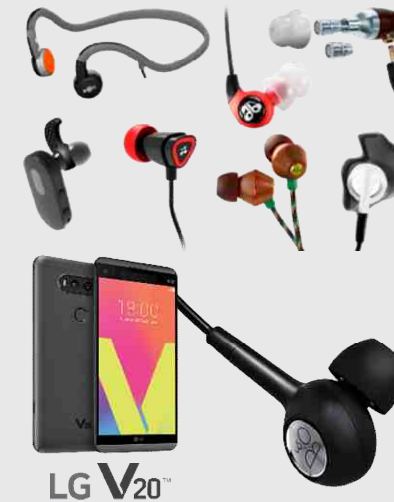

모바일 기기의 청각 UI 착용성 향상을 위한 3차원 귀 형상 기반 이어폰 설계

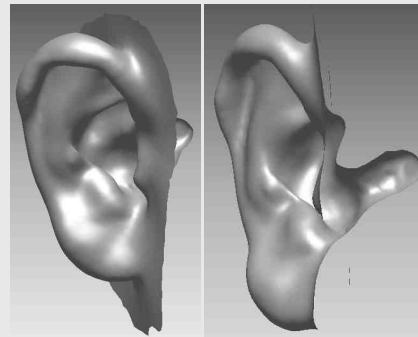
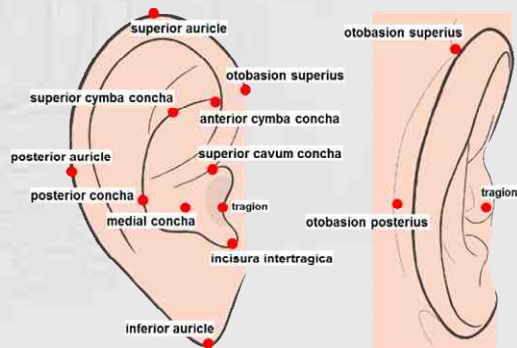

최영근¹, 정하영¹, 이원섭², 길혜진³, 배진완³, 유승훈³, 서기열³, 이정훈³, 유희천¹

¹포항공과대학교 산업경영공학과 인간공학설계기술 연구실

²Delft University of Technology

³LG전자 MC 디자인 연구소

목차

- Introduction
 - ✓ Background
 - ✓ Objectives of the Study
 - Collection of 3D Ear Scans
 - Anthropometric Analysis of 3D Ear Scans
 - Application of 3D Ear Scans to Earphone Design
 - Discussion
-

3D Scan Data의 유용성

- 복잡한 인체 형상에 대한 세부 측정치 정보(예: curvature, area, and volume)는 다양한 제품 설계에 유용하게 활용될 수 있음

Application of 3D scan images to product design

Representative head form analysis of 2,300 head images for head wearable products



Virtual fit analysis for design of pilot's oxygen mask by applying 3D facial shapes of 336 Korean pilots

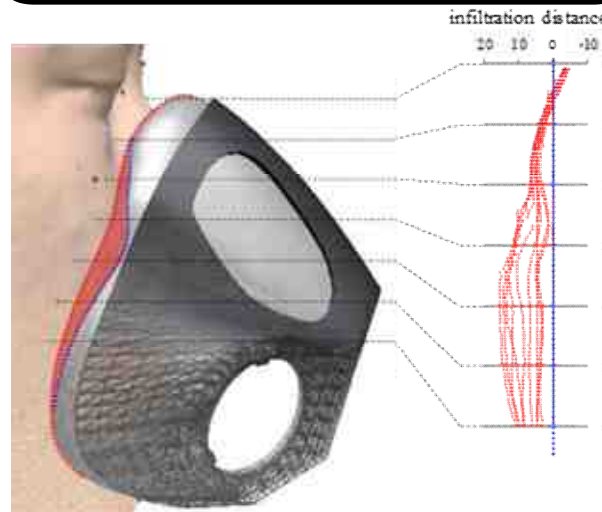

3D shape analysis of 300 Korean faces for design of dust-proof mask

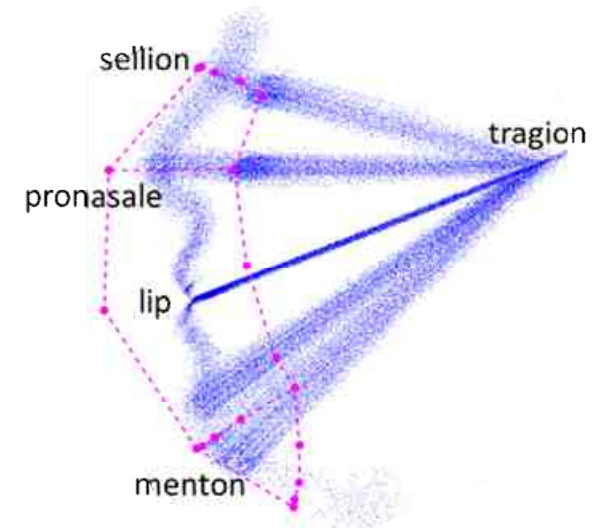

3D Ear Anthropometry의 필요성

□ 이어폰의 유형과 형태가 **다양하고 복잡함**

⇒ 착용감이 좋은 이어폰의 설계를 위해 **세부적인 귀 측정 정보가 필요함**

□ **3D 귀 형상과 관련된 정보가 매우 한정적임**

⇒ 이어폰 설계에 필요한 세부적인 귀 치수 정보 수집이 필요 함

⇒ Pinna(귓바퀴) 부위와 earhole(귓구멍)을 포함하는 3D 귀 형상이 필요함

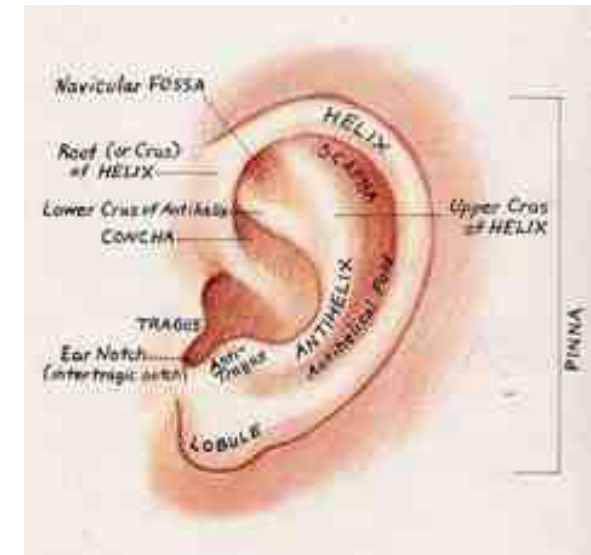
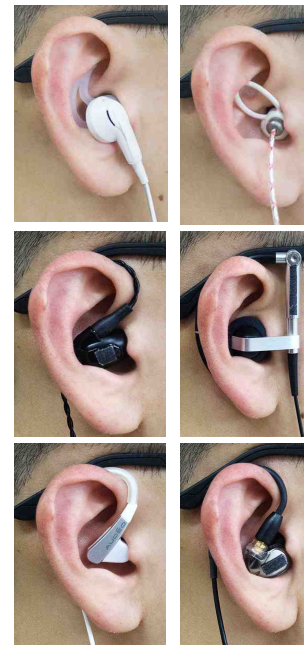

연구 목적

3차원 귀 형상 측정 및 이어폰 설계 적용

- **3D 귀 형상 측정:** 내·외국인의 귀 형상 측정

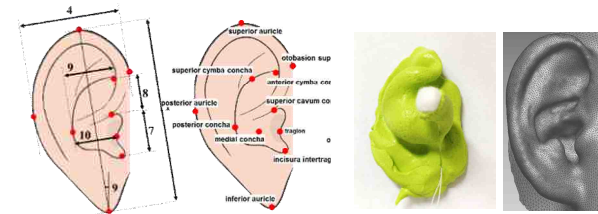

- **3D 귀 형상 분석:** 내·외국인의 귀 형상 분석

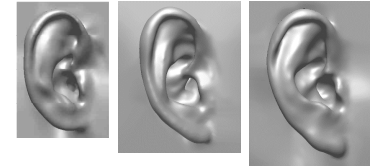

- **이어폰 주요 부품 설계:** 부품별 인간공학적 설계 전략 수립

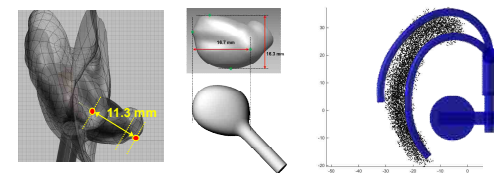

- **가상 착의 분석:** 3차원 가상환경에서 착의 후 여유량 및 압박량 분석

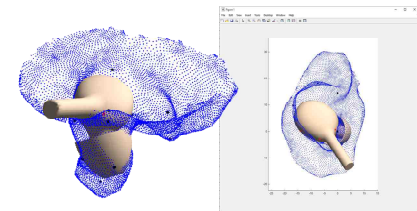

실험 참여자

□ 다양한 귀 형상을 고려한 이어폰 설계를 위해 **20대 ~ 50대 296명의 귀를 측정함**

➢ 한국인 200명: 남성 100명, 여성 100명

➢ 북미인 96명: 남성 50명, 여성 46명

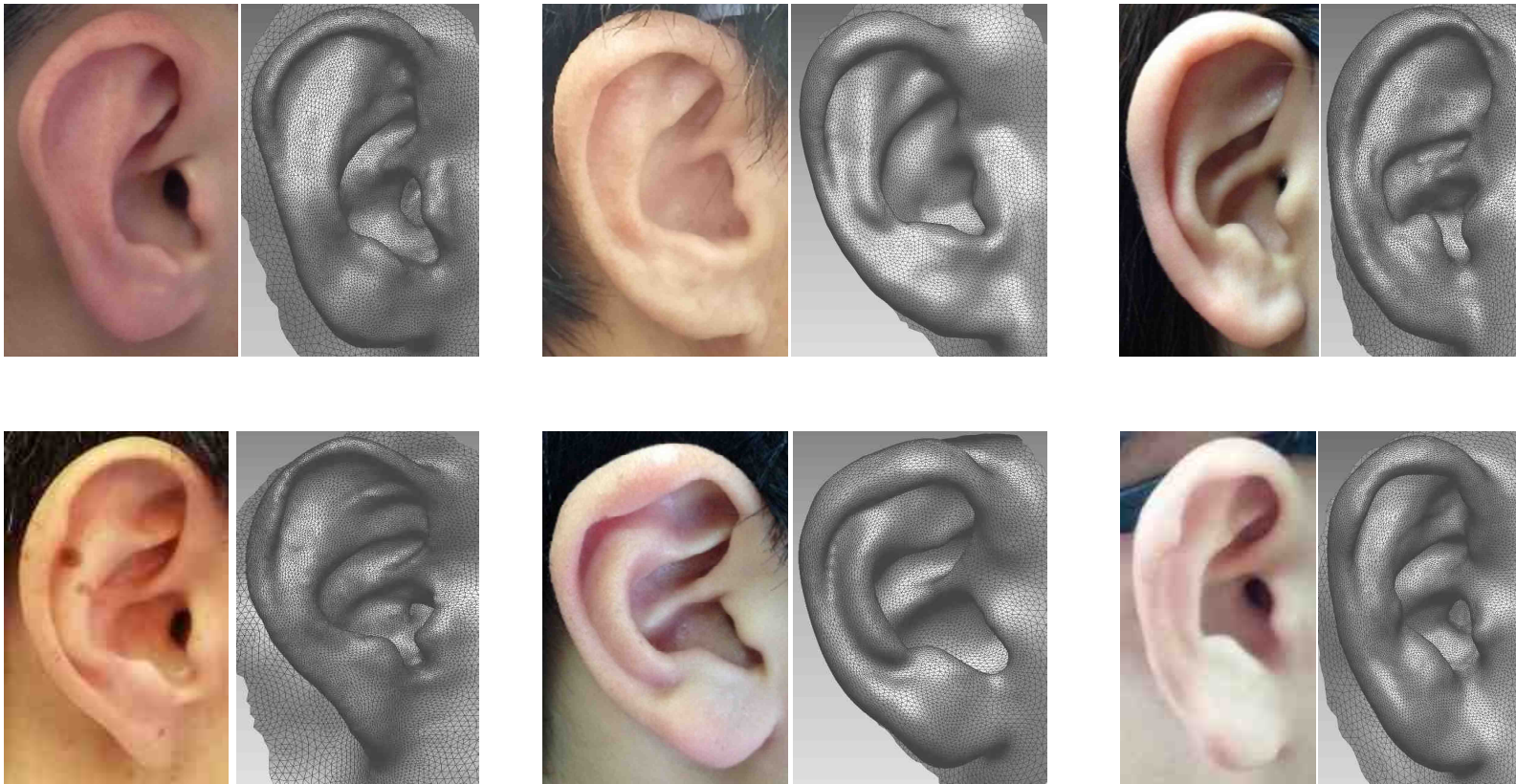

3차원 귀 형상 측정 및 분석

- 귀 형상 측정 및 분석을 위해 3D scanning 및 후처리(post-processing) 수행
- 귀 관련 기준점(landmark), 측정항목(dimension) 선정 후 형상 및 치수 분석

3D 형상 측정 절차

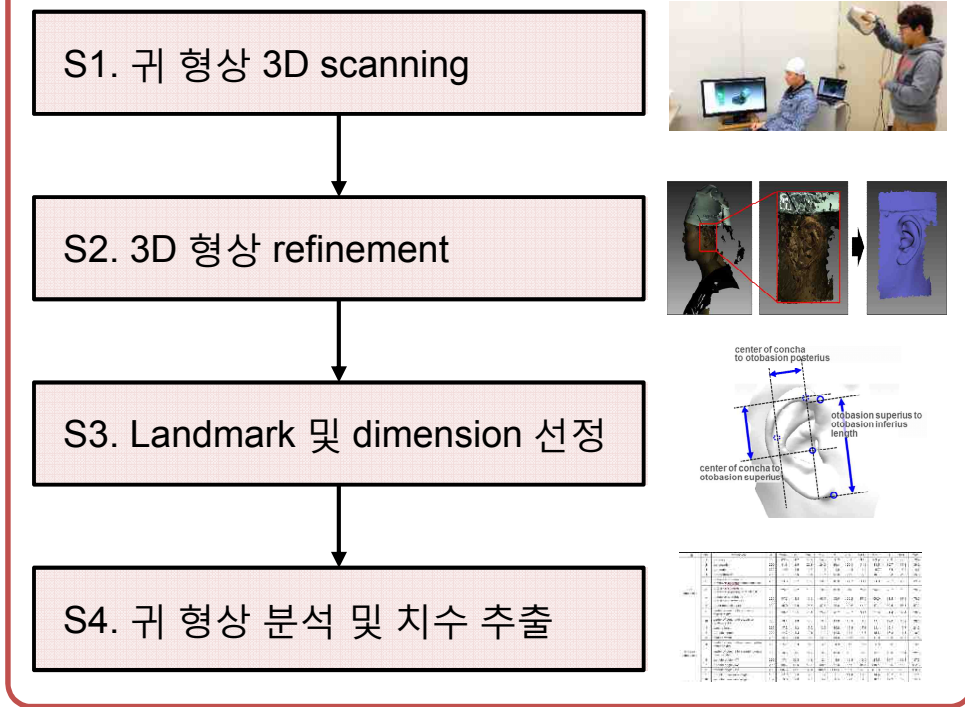

3D 형상 측정 결과



귀 Scanning 및 Editing 절차

귀 scanning (8 min)

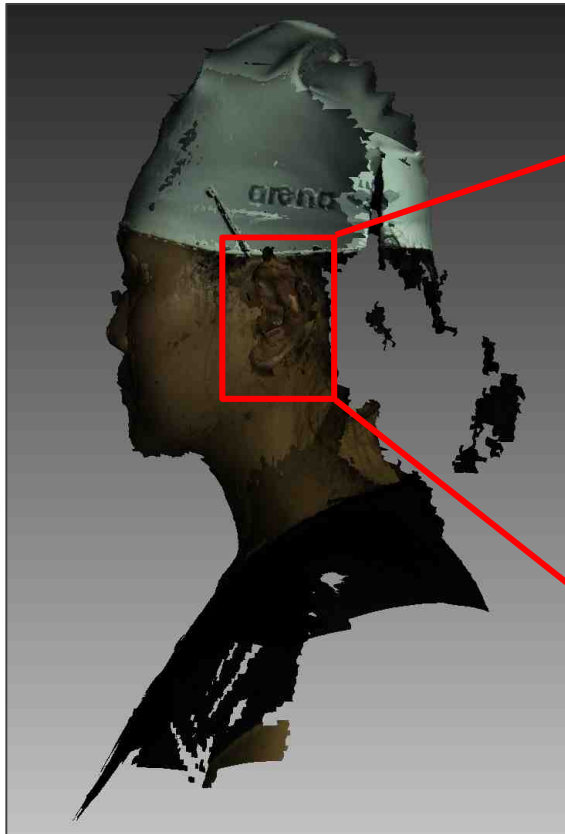

귀 부위만 남기고 제거



Editing (25 ~ 50 min)



Ear Canal Casting 및 Editing 절차

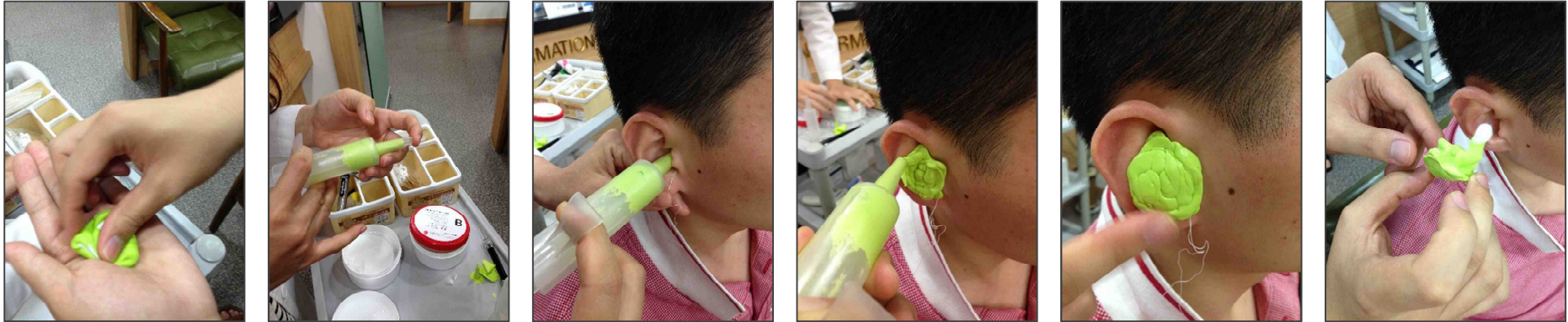

Casting된 귀



Cast의 3D scanning
(5 min)

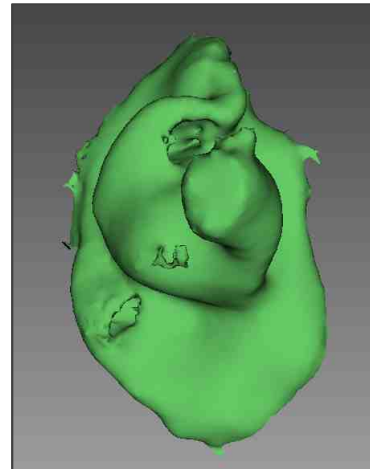

Cast의 post-processing
(15~30 min)

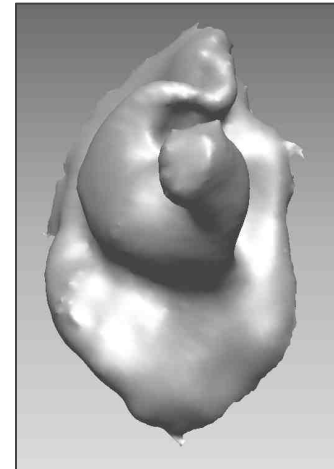

Inverse

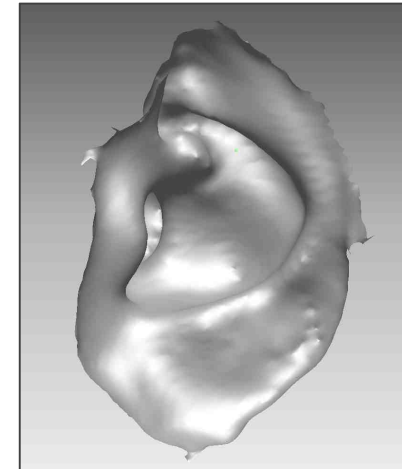

3D 귀와 3D Cast의 Merge

귀 3D scan



귀 cast의 3D scan

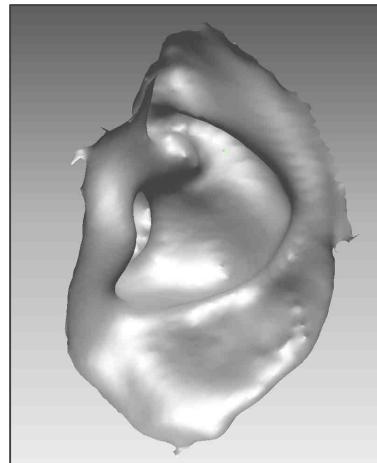

+

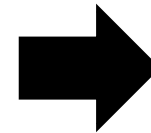

귀와 cast의 merge된 형상

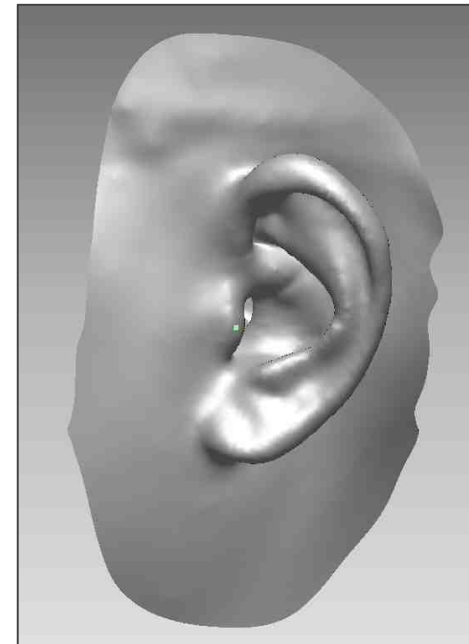

3차원 귀 형상 분석: 측정 항목 및 Code

□ 23개 측정 항목(귀 전반: 10; concha 부위: 9; ear canal 부위: 7) 선정

범주	측정 항목 수	귀 측정 항목	Code
귀 전반 (10)	Length	<ul style="list-style-type: none"> • ear length • otobasion superius to otobasion posterius horizontal length • otobasion superius to otobasion posterius vertical length • center of concha to otobasion posterius length • center of concha to otobasion superius length 	EL01 EL04 EL05 EL06 EL07
	Width	<ul style="list-style-type: none"> • ear breadth • ear protrusion 	EW01 EW02
	Circumference/Arc	<ul style="list-style-type: none"> • upper otobasion arc 	EC01
	Angle	<ul style="list-style-type: none"> • ear angle • pinna flare angle 	EA01 EA02
Concha 부위 (9)	Length	<ul style="list-style-type: none"> • cavum concha length • center of concha to anterior cymba concha length • center of concha to superior cymba concha length • superior cavum concha to anterior cymba concha length • posterior concha to anterior cymba concha length • center of concha to incisura intertragica length 	CL01 CL04 CL05 CL06 CL07 CL08
	Width	<ul style="list-style-type: none"> • cavum concha width 	CW01
	Depth	<ul style="list-style-type: none"> • cavum concha depth 	CD01
	Circumference/Arc	<ul style="list-style-type: none"> • cavum concha curvature 	CC01
Ear canal 부위 (7)	Length	<ul style="list-style-type: none"> • ear canal length 	ECL01
	Width	<ul style="list-style-type: none"> • ear canal width 	ECW01
	Depth	<ul style="list-style-type: none"> • ear canal depth 	ECD01
	Angle	<ul style="list-style-type: none"> • ear canal azimuth angle of the 1st bend • ear canal elevation angle of the 1st bend • ear canal azimuth angle of the 2nd bend • ear canal elevation angle of the 2nd bend 	ECA01 ECA02 ECA03 ECA04

귀 측정 항목 예

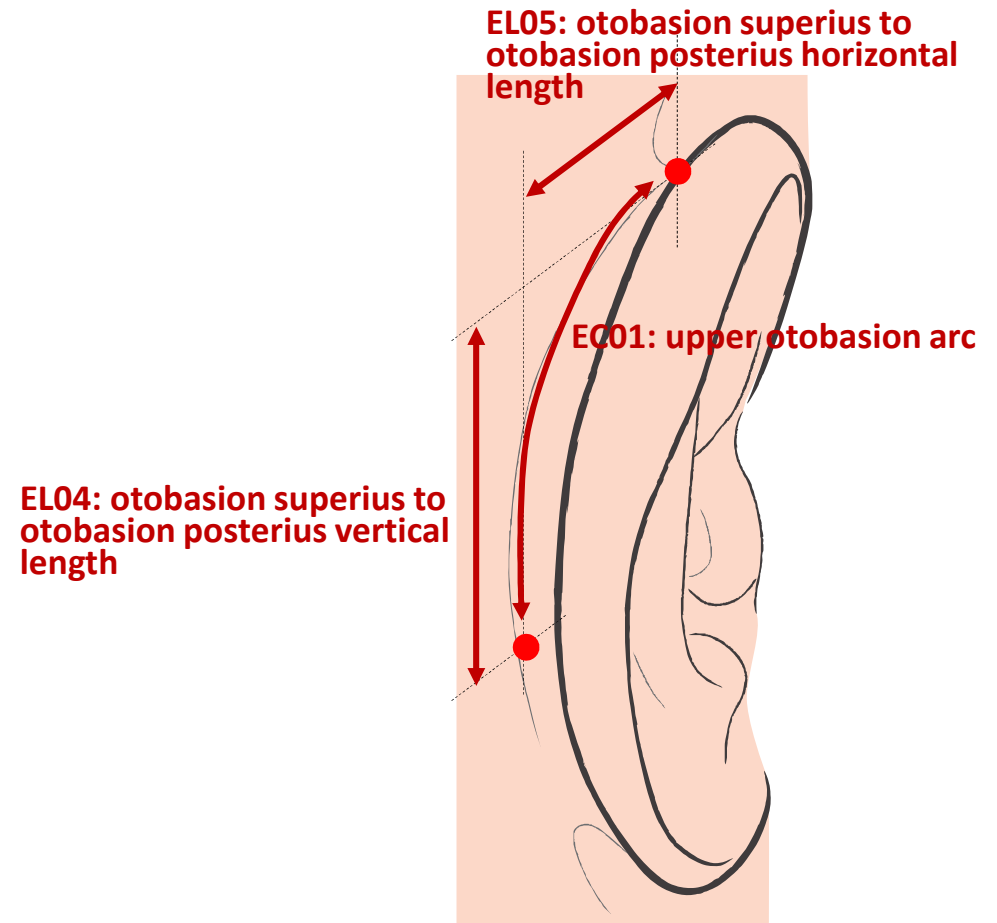
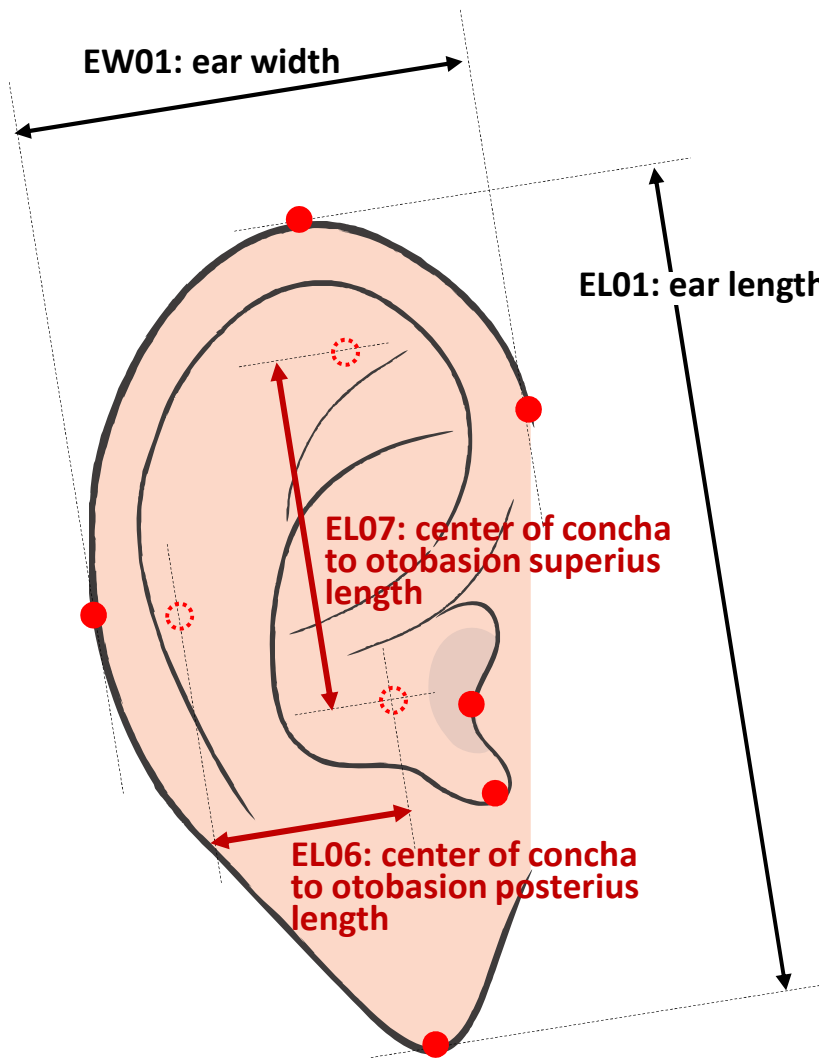

3차원 귀 형상 분석 결과





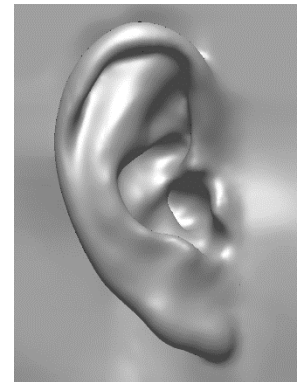

□ Ear dimension별 percentile 추정 값을 적용 및 보정하여 대표 귀 선정

	EL01	EL04	EL05	EL06	EL07	EW01	EC01	EA01	EA02	CL01	CL04	CL05	CL06	CL07	CL08	CW01	CW02	ECL01	ECW01	ECD01	ECA01	ECA02
	ear length	otobasion superior to otobasion posterius horizontal length	otobasion superior to otobasion posterius vertical length	center of concha to otobasion superior length	center of concha to otobasion posterius length	Ear breadth	upper otobasion curvature	pinna rotation angle	pinna flare angle	avum concha length	center of concha to anterior cymba concha length	center of concha to superior cymba concha length	superior cavum concha to anterior cymba concha length	posterior concha to anterior cymba concha length	center of concha to incisura intertragica length	cavum concha width	cavum concha depth	ear canal length	ear canal width	ear canal depth	ear canal azimuth angle	ear canal elevation angle
1st	71.0	21.0	15.0	18.0	18.0	18.0	18.0	18.0	18.0	18.0	18.0	18.0	18.0	18.0	18.0	18.0	18.0	18.0	18.0	18.0	18.0	18.0
5th	71.0	21.0	15.0	18.0	18.0	18.0	18.0	18.0	18.0	18.0	18.0	18.0	18.0	18.0	18.0	18.0	18.0	18.0	18.0	18.0	18.0	18.0
50th	71.0	21.0	15.0	18.0	18.0	18.0	18.0	18.0	18.0	18.0	18.0	18.0	18.0	18.0	18.0	18.0	18.0	18.0	18.0	18.0	18.0	18.0
95th	71.0	21.0	15.0	18.0	18.0	18.0	18.0	18.0	18.0	18.0	18.0	18.0	18.0	18.0	18.0	18.0	18.0	18.0	18.0	18.0	18.0	18.0



이어폰 주요 부품 설계

- 이어폰 유형별 설계 대상 세부 부품들을 정의함
- 주요 부품으로 ear-tip, housing, ear-band를 선정함

Component		Type	Canal	Open
				
Ear-tip	Tip 		O	X
	Nozzle 		O	X
Housing	Body 		O	O
	Hook 		O/X	O/X
Ear-band			O/X	O/X

이어팁 설계: Ear Canal Length/Width Ratio 분석

- Ear canal의 length 대비 width의 비율(length/width ratio)의 **개인간 차이 큼(0.7 ~ 2.4)**
⇒ **다양한 비율의 귀 형상, 착용 편의성**을 위해 **이어팁을 원형으로 설계** 추천(타원형 이어팁은 정확한 착용을 위한 각도 조절이 번거로움)

이어팁 설계: 이어팁 Diameter별 수용률 분석

(n = 30)

- Small (10.8 mm), Medium (12.0 mm) 2가지 크기로 실험 참여자 그룹(n = 30)의 93.3% ~ 96.6%의 귀 크기를 수용하는 것으로 나타남
- 실리콘팁은 66% ~ 84%, 폼팁은 75% ~ 85% 수용 가능한 것으로 파악됨

이어팁 설계: 높이 분석

□ 이어팁 시작점에서 ear canal 벽면까지의 거리 분석

□ 여유량을 적용하여 이어팁 높이 설계안

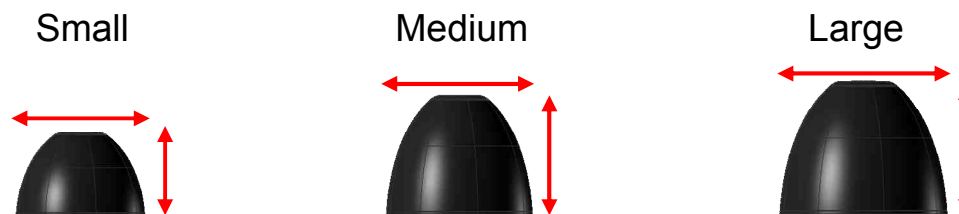

하우징 설계: 연관 귀 치수 및 설계 치수 분석

Small (25th %ile 기준)

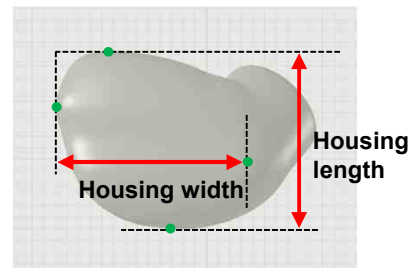

Medium

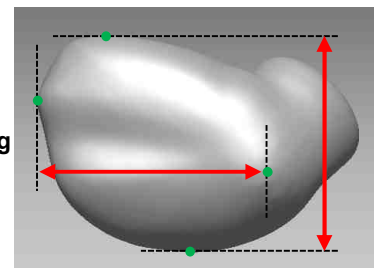

Large (75th %ile 기준)

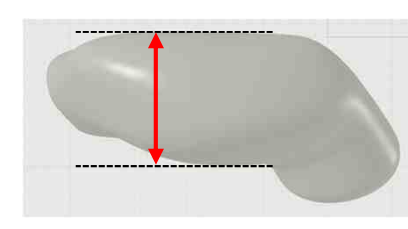
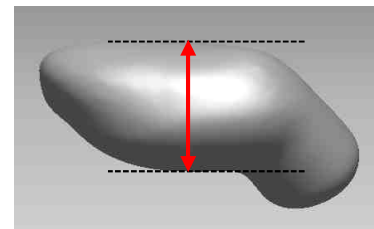
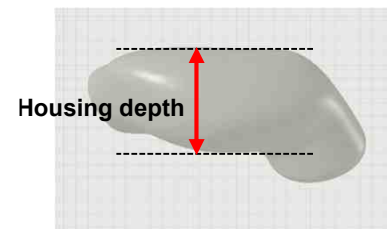
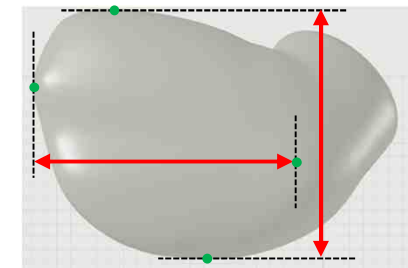

신규 하우징 설계안

Medium

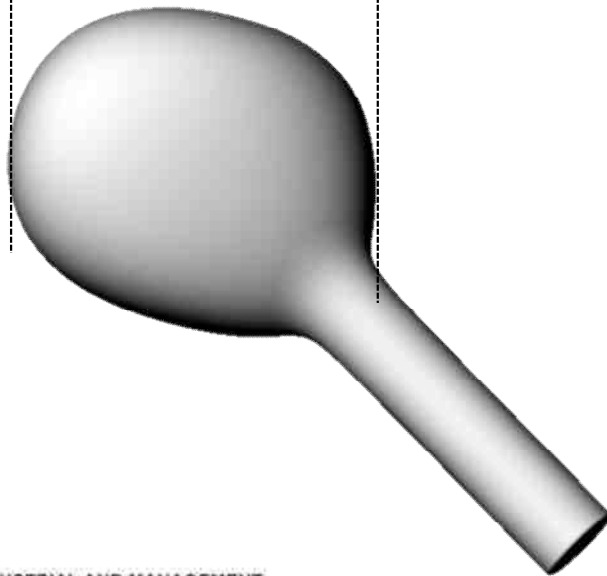
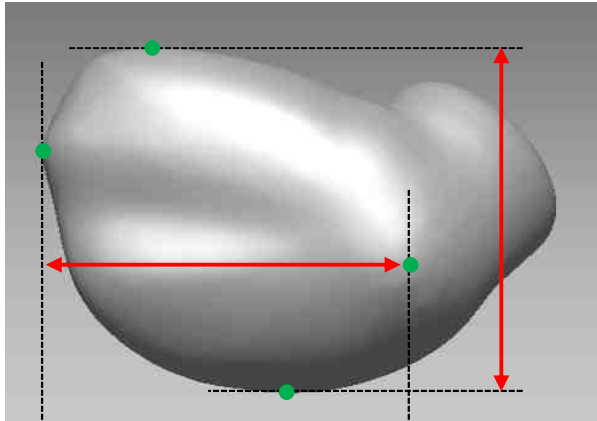

Ear-band 설계: 귀뿌리 형상 분석

- 귀뿌리 대표 형상을 기반으로 설계 하되 고정성 증진을 위해 하단부는 약간 조이도록 설계함

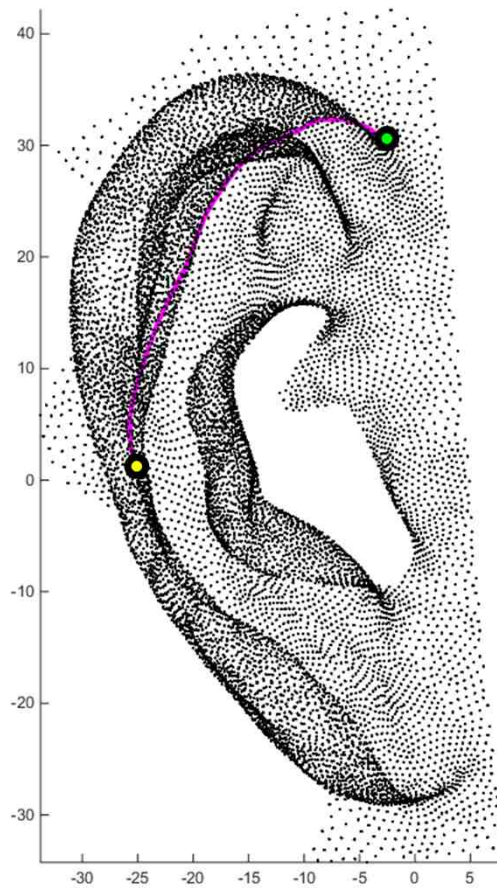

대표 귀뿌리 기반
earband 형상

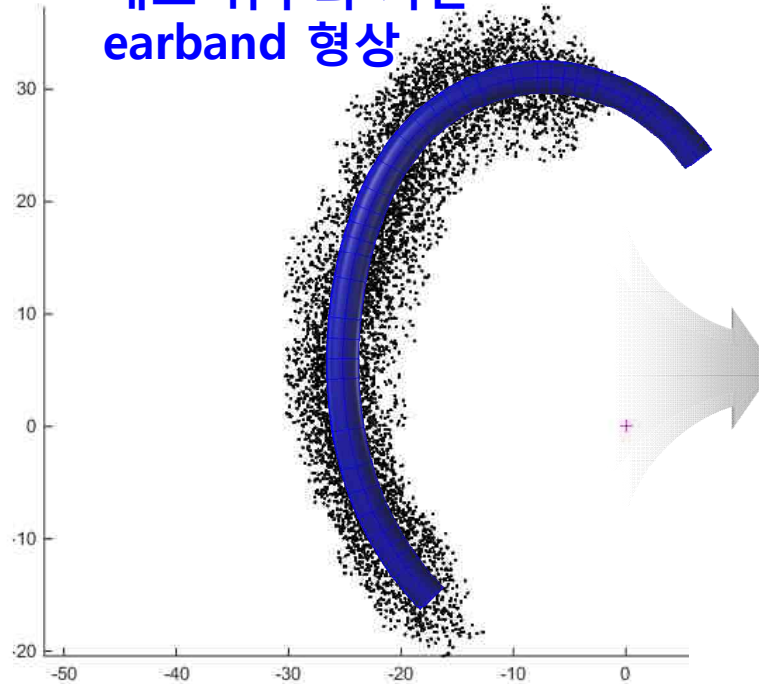

고정성 향상을 위해
하단부가 변형된 형상

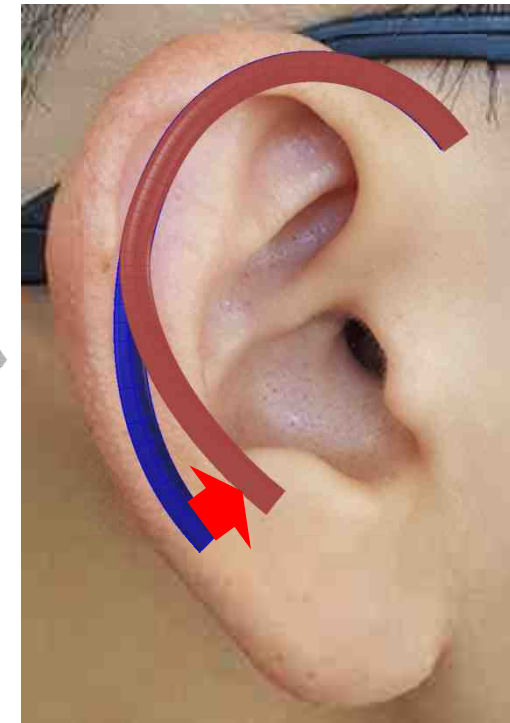

신규 Ear-band 설계안: 고정형

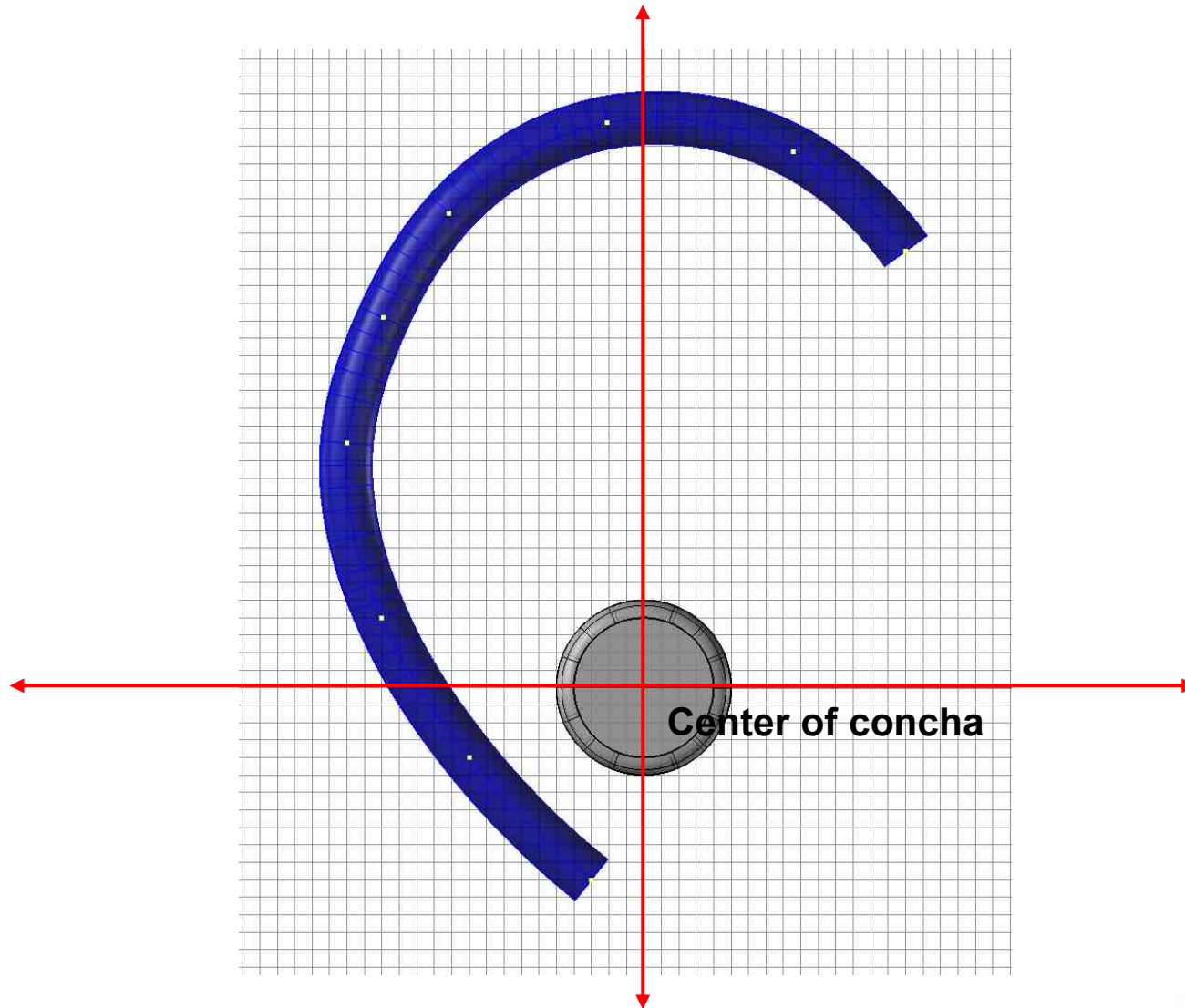

신규 Ear-band 설계안: 회전형

- 귀뿌리 대표 형상을 기반으로 설계 하되 **hinge**를 활용하여 다양한 크기의 귀 형상을 **수용**할 수 있도록 설계함

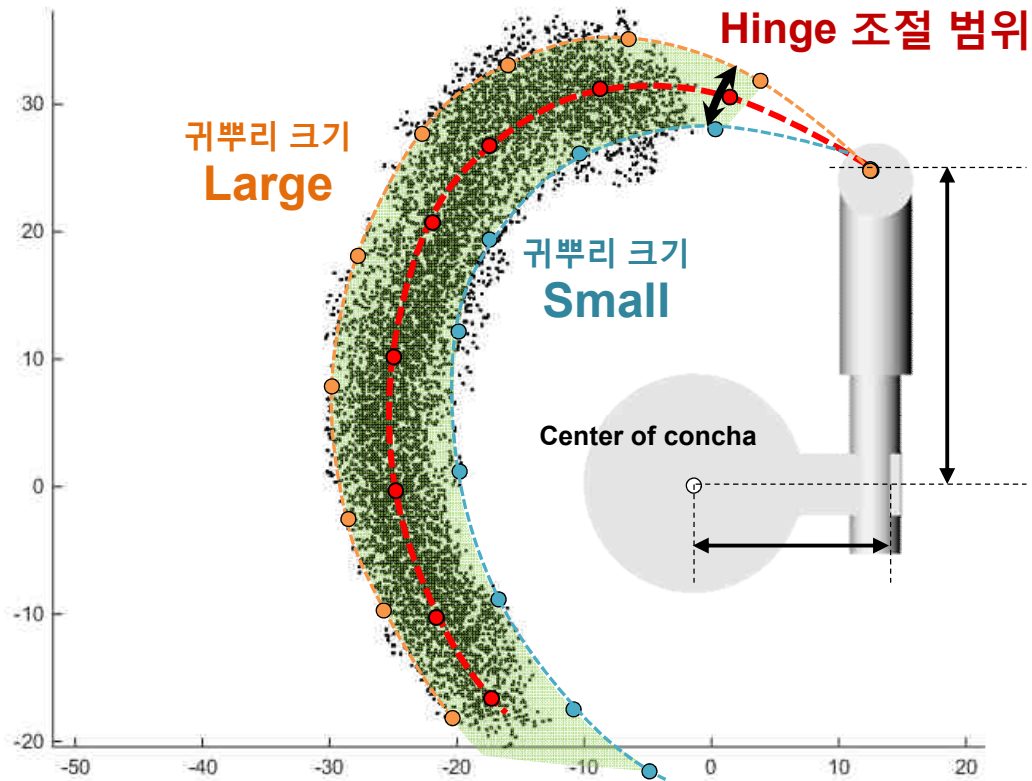

가상 착의 분석 (1/2)

□ 설계된 이어폰에 가상 착의 시 **압박/여유공간 분석 기준**이 되는 **landmark**를 표기함

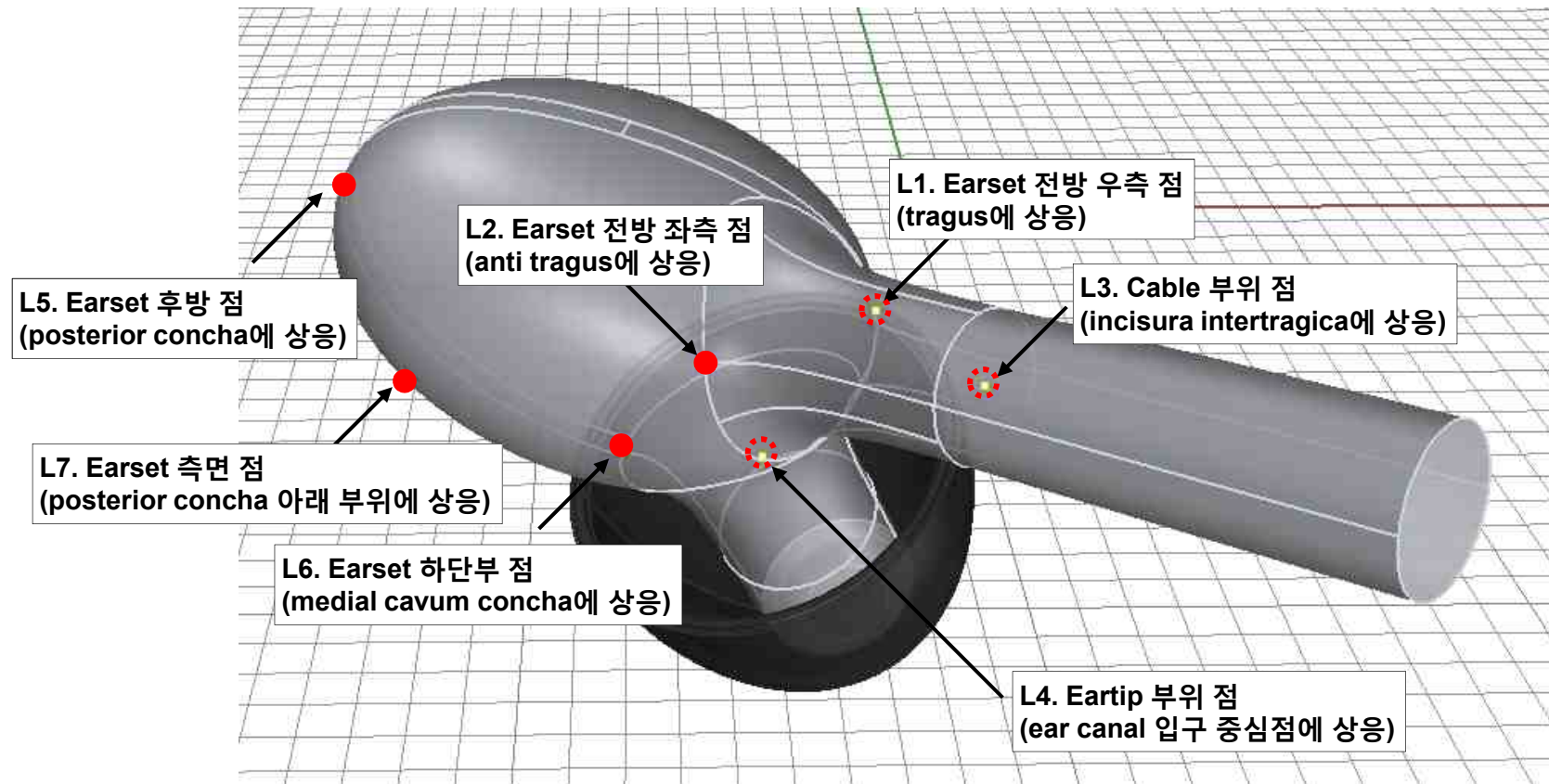

가상 착의 분석 (2/2)

- 이어폰 설계 상에 표기한 landmark와 3차원 귀 형상의 landmark를 이용하여 가상 착의 시키고, 압박/여유공간을 분석함

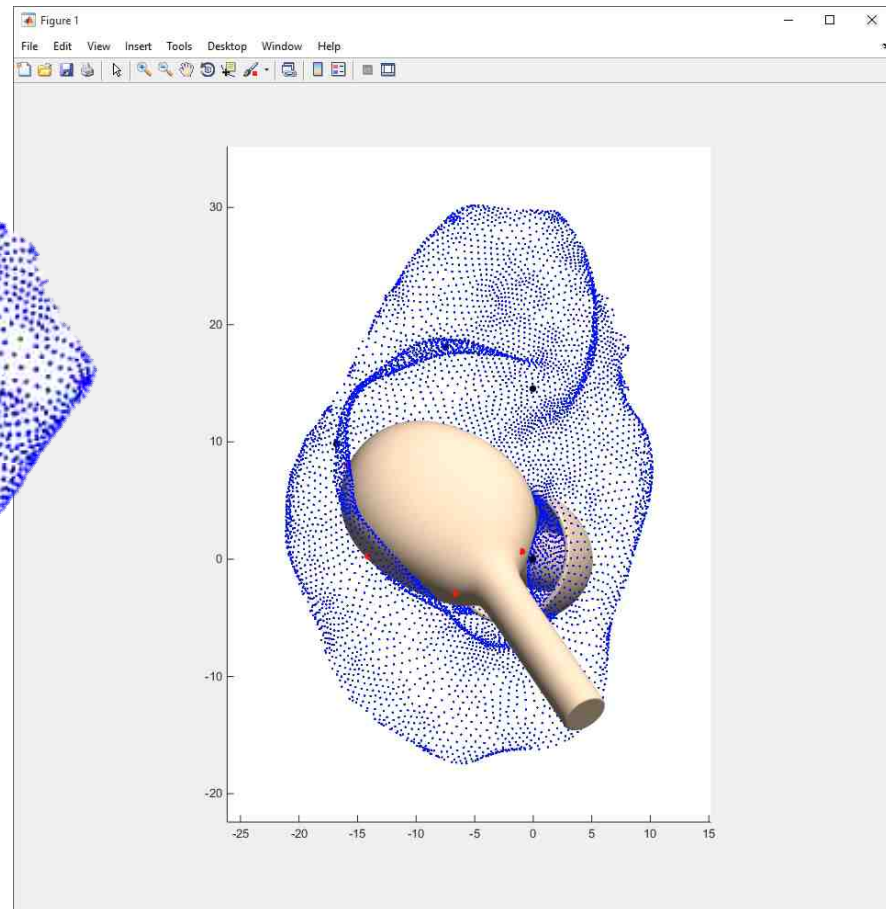
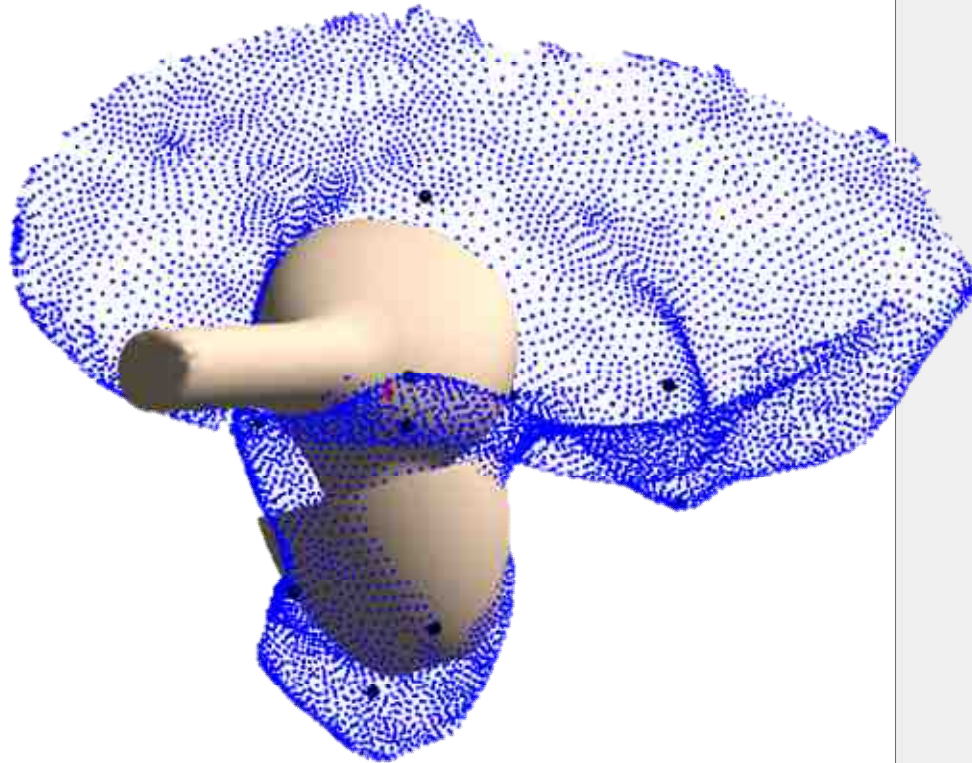

가상 착의 분석 결과: 신규 설계안 vs. W사

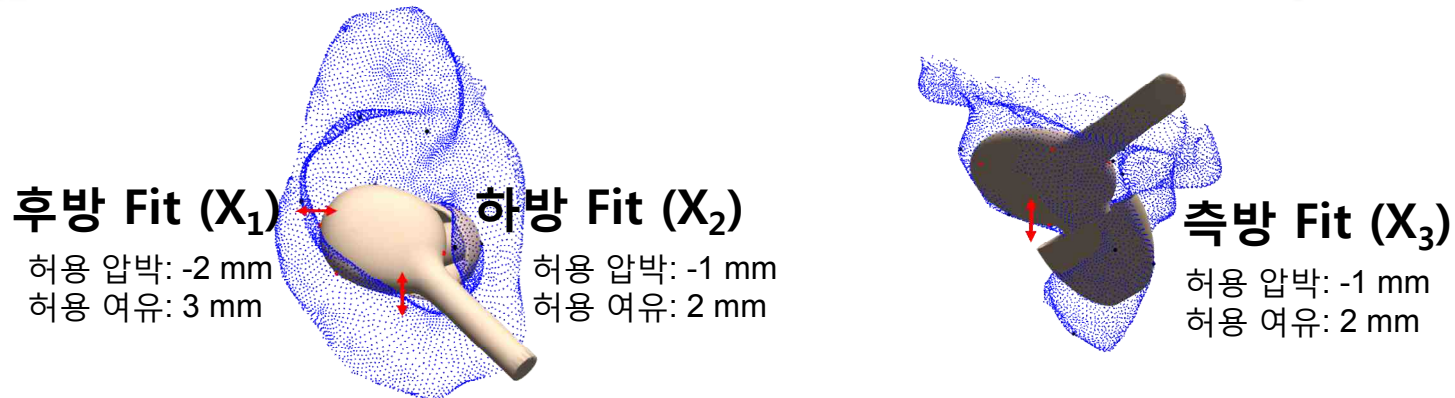

신규 하우징	X_1	X_2	X_3	Mean	Min.
적절	94%	93%	92%	93%	92%
과도 압박	0%	5%	3%		
과도 여유	6%	2%	5%		

W사	X_1	X_2	X_3	Mean	Min.
적절	85%	91%	67%	81%	67%
과도 압박	15%	7%	19%		
과도 여유	0%	2%	14%		

Discussion (1/4)

□ Scanning, casting, editing, 그리고 merging 절차를 통해 **pinna와 earhole 부위를 포함하는 3D ear scan data를 수집함**

⇒ 귀 착용 제품(이어폰, 보청기, 헤드폰, 안경, 고글 등) 설계에 유용하게 활용될 수 있음



Discussion (2/4)

- 전반적 귀 치수들을 기반으로 **5개의 대표 귀 형상 (2.5, 25, 50, 75, and 97.5%iles)**을 도출함

Smallest
(2.5%ile)



Small
(25%ile)



Medium
(50%ile)



Large
(75%ile)



Largest
(97.5%ile)



Discussion (3/4)

□ Ear scan data를 이어폰 설계에 적용함

1. 귀 크기별 선호 earbud 크기 분석(e.g., diameter of earbud)
2. Ear-band 설계를 위한 귀뿌리 형상 분포 분석
3. 이어폰 각 부위별 착용 적절성 평가를 위한 가상 착의 분석

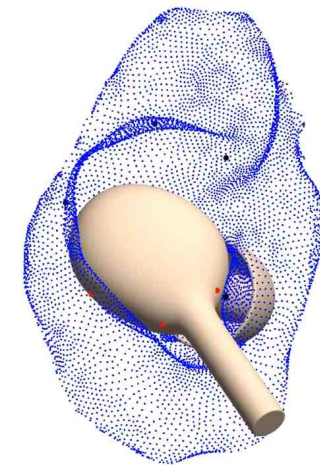
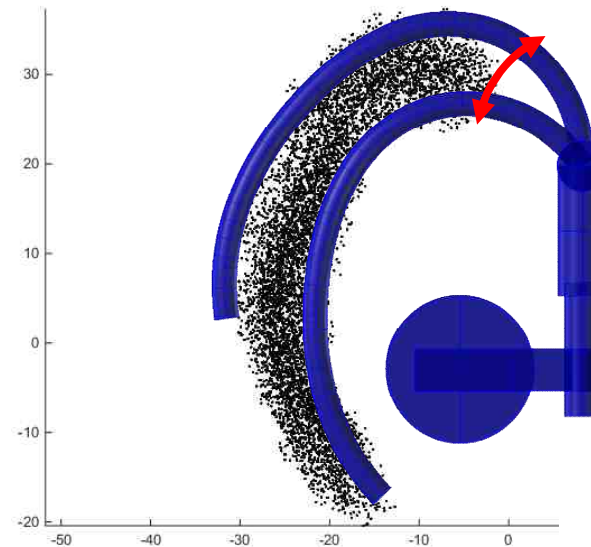
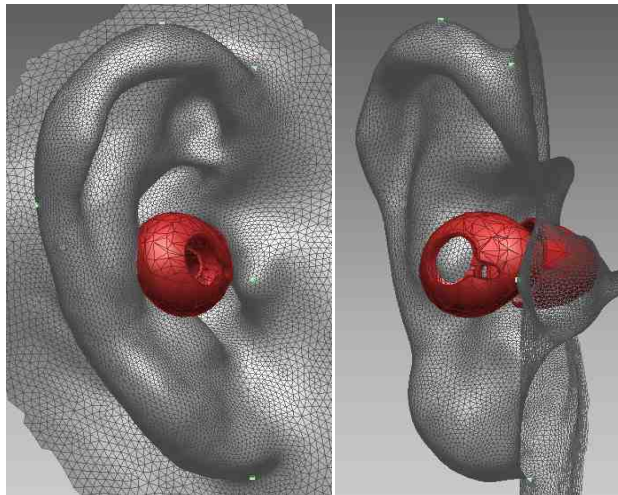

Discussion (4/4)

- 2016년 LG V20과 함께 제공되는 이어폰 형상 설계에 적용



Q&A

감사합니다.

